

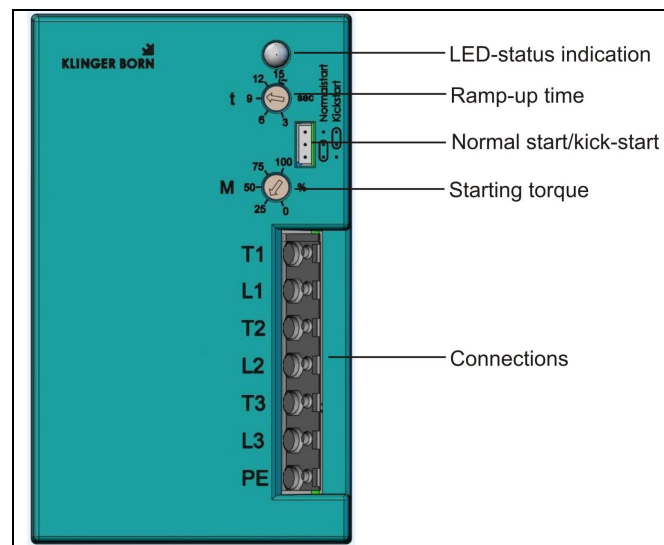

## Softstarter: Explanation of connection and function



LED status indication	Explanation	Remedy
LED lights up red for about 100 ms	LED test when the softstarter is switched on	Indication of normal operation
LED flashes red	Fault indication: High temperature, restart not possible.	Let device cool for 15 minutes before restart; reduce switching frequency; provide sufficient cooling.
LED lights up red	Fault indication: Wrong direction of rotational field, phase missing or inverted, wrong frequency.	Check mains connection; replace fuse if necessary; change rotational field.
LED lights up red (current controlled version)	Time-out	Start-up was not achieved; increase torque.
LED flashes green	Ramp-up phase	Indication of normal operation
LED flashes red and green (alternating)	Adjustment mode activated. No continuous operation!	Type S1 is in adjustment mode. Set the ramp-up time after adjusting the torque. This mode must not be used for continuous operation.
LED lights up green	Operation	Normal operation; switched to bypass.

Jumper setting	Explanation	Remedy
siehe Abbildung	 <p>Use jumper to activate kick-start function for motors up to 5.5 kW. For heavy-duty start-up with high static friction the motor is actuated for approx. 120 ms with a very high torque.</p>	The kick-start function may be activated if the drive fails to start even with a higher torque setting. Change the position of the jumper according to the figure.

<b>Setting potentiometer</b>	<b>Explanation</b>
Ramp-up time (t)	<p>Setting range 3 ... 15 seconds (only version without current control)</p> <p>Please note that the start-up current increases considerably with very short ramp-up times. Therefore avoid setting too short ramp-up times. Depending on the motor and the rotating mass tried and tested times range between 6 and 12 seconds.</p> <p><u>Caution:</u> Turning the potentiometer all the way to the right (~15) sets the device to adjustment mode. The ramp-up time is frozen, the start-up current (starting torque) alone determines the ramp-up time. Once you have found the correct value, set the time to the ramp-up time you have determined.</p> <p>The bypass relays will not be activated in adjustment mode. This is indicated by alternating red and green flashing of the LED.</p> <p>Never use this mode for normal operation !</p>
Starting torque (M)	<p>This potentiometer sets the starting torque. High power motors (&gt; 4.0 kW) have coils with a very low resistance, in particular motors with star connection. This causes very high start-up currents, even with a torque setting as low as 50%. Here the setting should never exceed 50%. Field tests have shown that a setting of 25% is absolutely sufficient. The current controlled version features an overload protection. A torque setting of 0 ... 100% causes a phase current of 8 ... 40 A. If the start-up is not achieved or not detected after 30 seconds, a time-out will switch off the device. This is indicated by a red lit LED.</p>

<b>Connection</b>	<b>Explanation</b>
T1	Motor connection U
L1	Supply network phase L1
T2	Motor connection V
L2	Supply network phase L2
T3	Motor connection W
L3	Supply network phase L3
PE	Protective ground connection