

# Quick guide of PI500 Operation

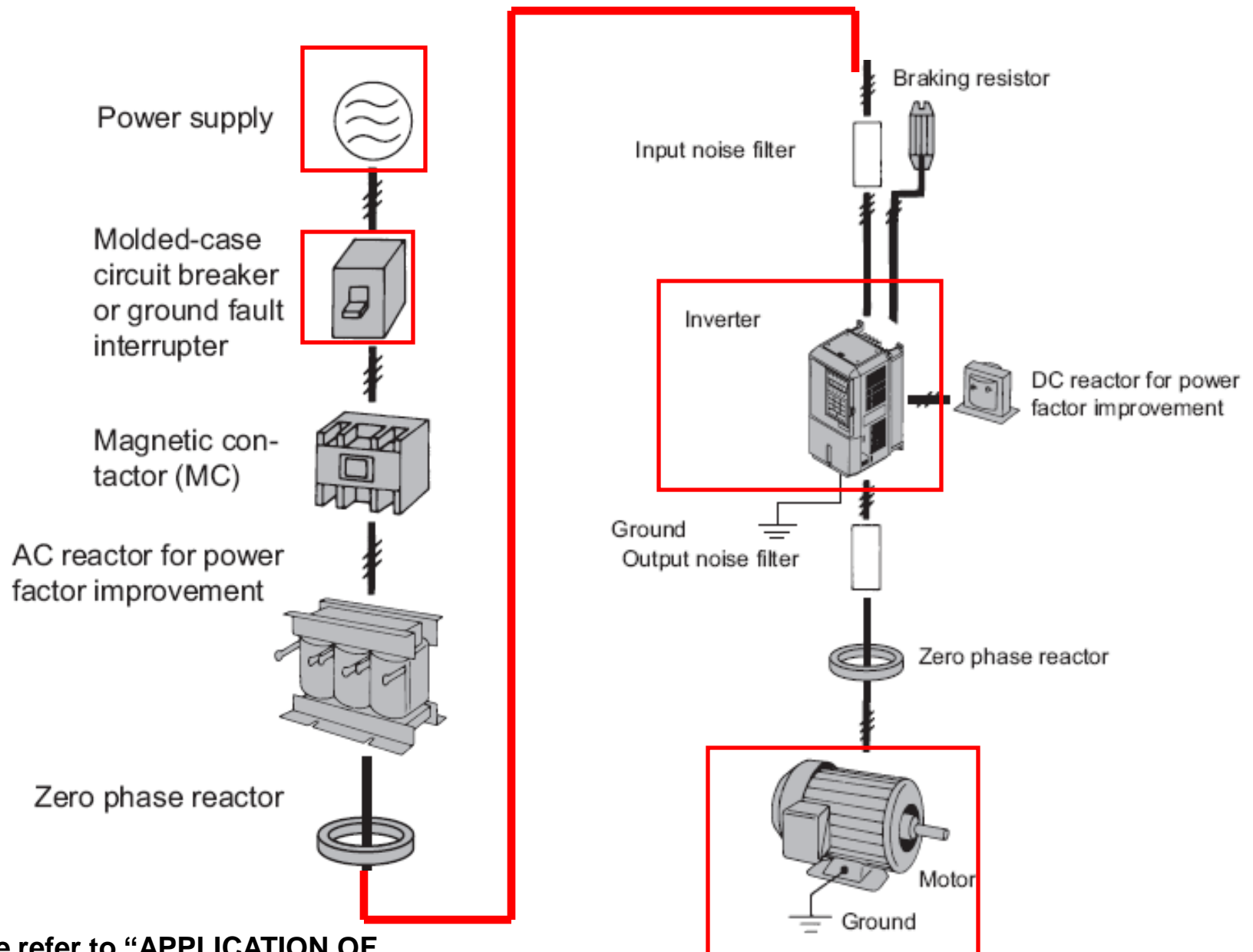

**PI500 High Performance vector control inverter**

# 1. connections between Inverter and peripheral devices.



Please refer to “APPLICATION OF OPTIONAL EQUIPMENT ”.

## 2.Keyboard operating instruction.

The operation keypad panel provides a way to start and stop the motc and adjust the operating speed.



Operation panel



**Parameter Setting/Exit Key.**

- \* Enter top level menu
- \* Exit from function option changing.
- \* Return to status display menu



**Shift Key**

- \* Select circularly parameters
- \* select parameters when parameters modifying

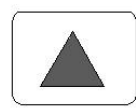

**Ascending Key**

- \* Data or function code ascending

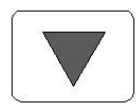

**Descending Key**

- \*Data or function code descending



**Enter Key**

- \*Setting confirm and into next menu.



**Run Key**

- \* Start motor in the keyboard mode.

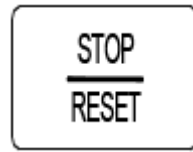

**Stop/Reset Key**

Stop motor / reset fault.



**Potentiometer**

- \* Frequency adjusting when U0.03 be set to 4.

# 3. Trial operation follow chart

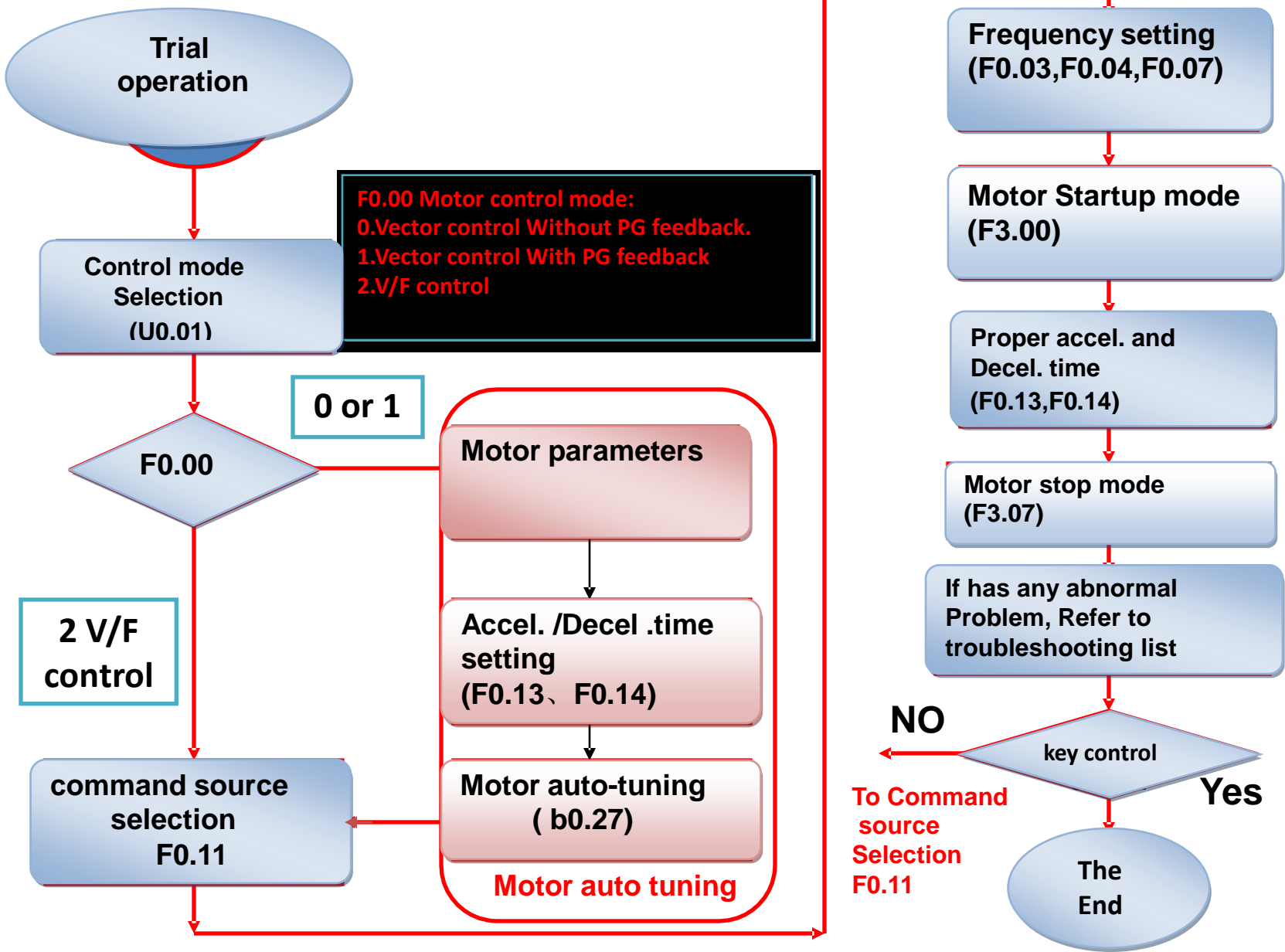

## 4. How to perform motor auto-tuning for vector control drive ?



Performing motor auto-tuning to catch accurate motor parameters is a **must** and important step, make motor work in good condition under vector control mode.

Auto tuning procedure. **For F0.00 be set to 0, Vector control Without PG feedback.**

- 1). Configure the motor b0 group parameters first. (b.00-b0.05).
- 2). Disconnect load from motor for performing comprehensive auto-tuning.
- 3). Configure b 0.27 to 1 and press RUN key, then auto-tuning will be perform.
- 4). Auto tuning time is up to F0.13,F0.14 setting. Normally you can forget this step.
- 5). If the load can't separate from the motor, please set b 0.27 to 1 to perform still auto-tuning.

b0.00	motor type	0: general asynchronous motor 1: asynchronous inverter motor 2: permanent magnet synchronous motor
b0.01	rated power	0.1 ~ 1000.0KW
b0.02	rated voltage	1 ~ 2000V
b0.03	rated current	0.01A~655.35A (rated power <=55KW) 0.1A~6553.5A (rated power >55KW)
b0.04	rated frequency	0.01 ~ F0.19 (maximum frequency )
b0.05	rated rotation speed	0 ~
b0.27	motor auto-tuning selection	0: no operation 1: asynchronous motor parameters still auto tuning 2: asynchronous motor parameters comprehensive auto tuning 11: synchronous motor parameters still auto tuning 12: synchronous motor parameters comprehensive auto tuning

# For F0.00 be set to 1, Vector control With PG feed back.

## Procedure:

1. Install optional PG card onto the controller board of inverter.
2. Wiring PG and encoder, refer to the manual **Appendix II**
3. Set the motor b0.00 group parameters first, also need to set more parameters according following table.
4. Configure b0.27 to 2, start motor auto tuning.
5. If the load can't separate from the motor, please set b 0.27 to 1 to perform still auto-tuning

F0.00	Control Mode	1.Vector control W/ PG	1
b0.27	motor auto-tuning selection	0: no operation 1: asynchronous motor parameters still auto tuning 2: asynchronous motor parameters comprehensive auto tuning	2
b0.28	Encoder type	0: ABZ incremental encoder/ 1: UVW incremental encoder/ 2: Rotational transformer/3: Sine and cosine encoder/4: Wire-saving UVW encoder	2500
b0.29	Encoder every turn pulse number	1 to 65535	0
b0.30	0.00 to 359.90	0.00 to 359.90	0.0
b0.31	ABZ incremental encoder AB phase sequence	0: forward 1: reverse	0
b0.32	UVW encoder offset angle	0.00 to 359.90	0
b0.33	UVW encoder UVW phase sequence	0: forward 1: reverse	0
b0.34	Speed feedback PG disconnection detection time	0.0s: OFF 0.1s to 10.0s	0.0s
b0.35	Pole-pairs of rotary	1 to 65535	1

# 5. Apply the braking unit and braking resistor .

The wires of braking unit connect to B1 and B2 terminal

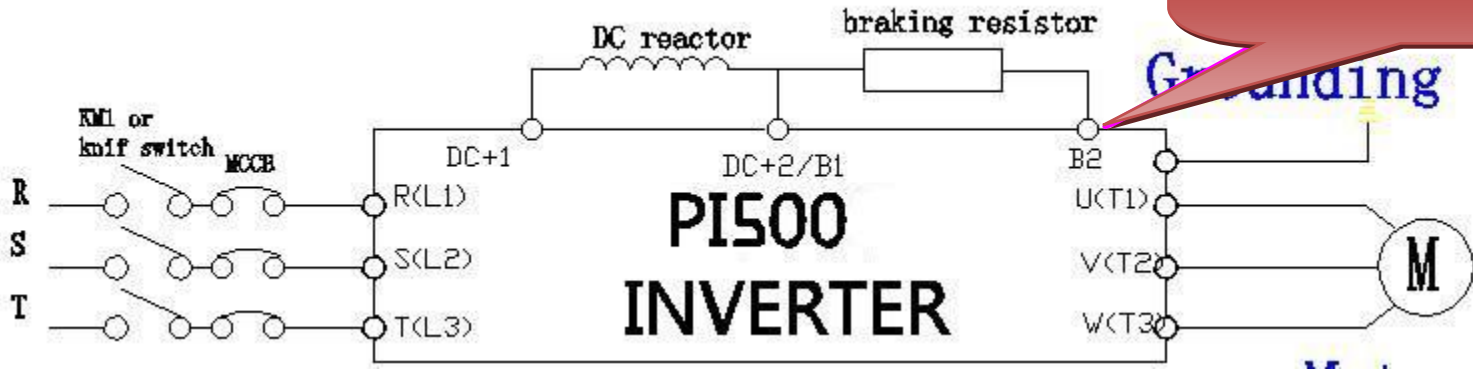

Inverter that below 22KW with built braking unit  
If you want to activated dynamic braking function, you need to connection Braking resistor.

**It is no need to set any parameters for connecting the braking unit .**  
**The braking function is activated in default ! The activated of DC braking Voltage is 130%  $U_{DC}$**



# 6. Operating the VFD with keyboard



**Parameter setting/exit**

**Setting confirmation**



**F0.03 set to 4, This potentiometer use for adjusting frequency**

**F0.11 set to 1, press this button will start inverter**

**Inverter stop, No output./ fault reset**



# 7. Operating VFD by I/O terminals board.

(I/O) terminals for connecting pushbuttons, switches and other operator interface devices or control analog signals.

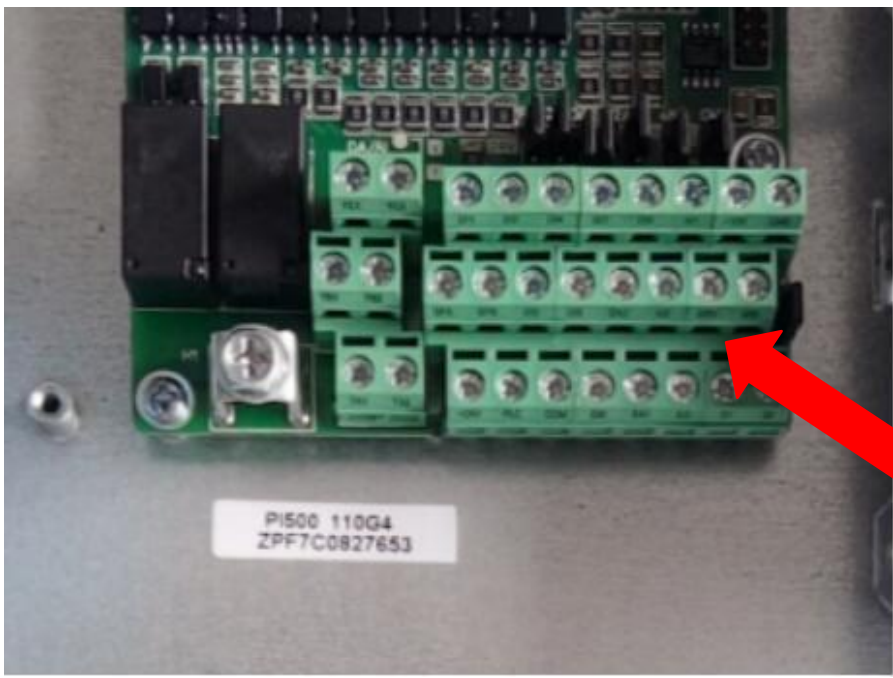

For example: Operating this Button connecting to I/O interface for controlling the Inverter .

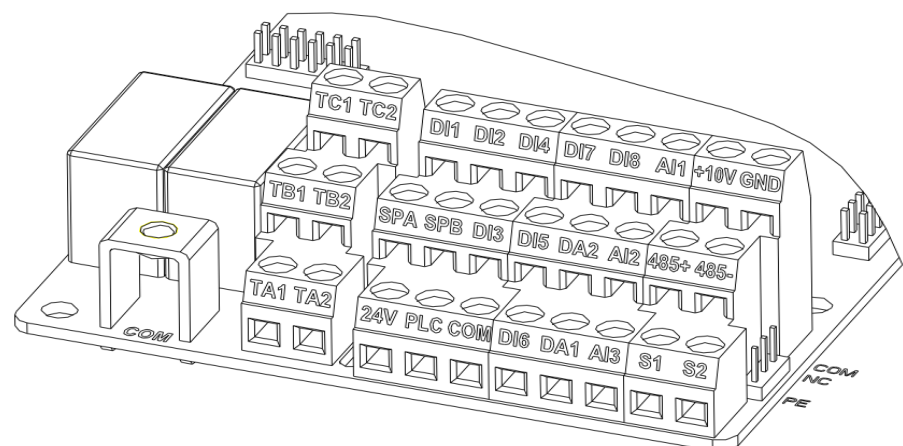

Operate VFD via operating panel

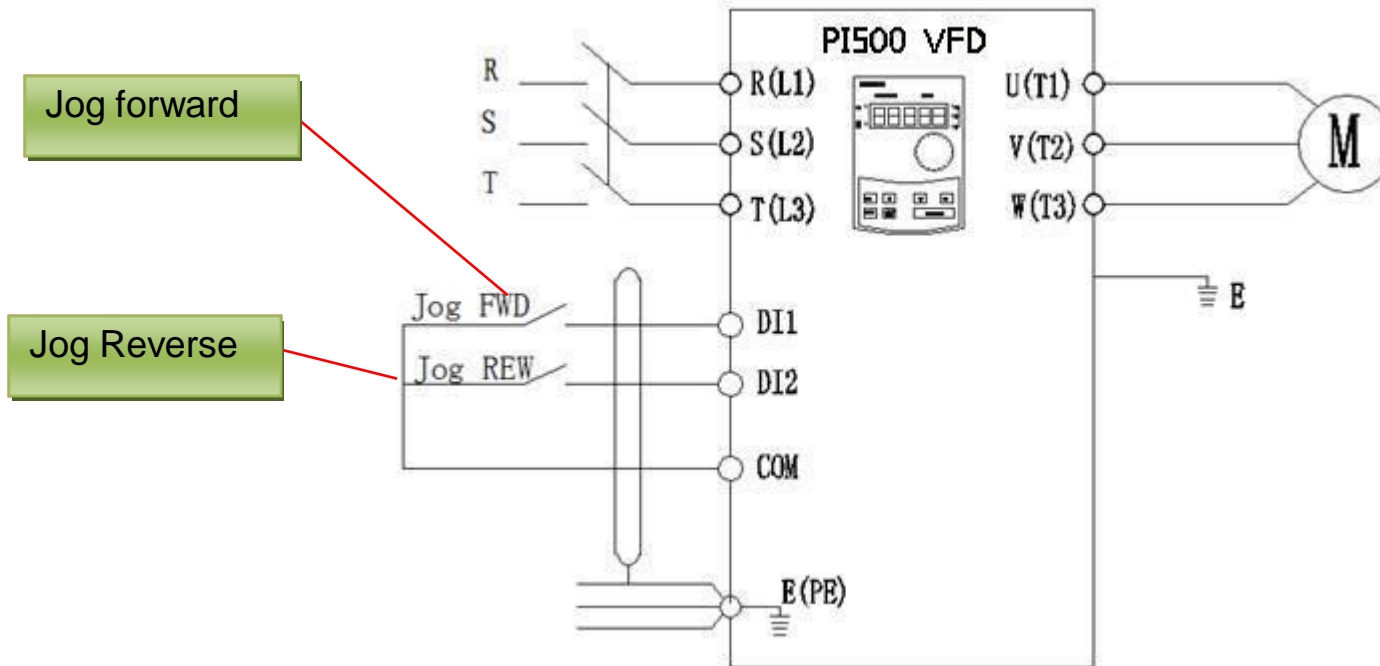

**JOG running control by button, please make setting as following table.**

F0.11	Running Control Mode	1:Terminal control	1
F1.00	(DI1 )Input Terminal Function Selection	FWD JOG command	4
F1.01	(DI2) Input Terminal Function Selection	REV JOG command	5
F7.00	Jog running frequency	0.00~F0.19(Maximum frequency)	2.00Hz
F7.01	Jog acceleration time	0.1~3600.0S	10
F7.02	Jog deceleration time	0.1~3600.0S	10
F7.03	Terminal jog priority	Invalid	0

# 9.FWD and REV running controlled by I/O terminal .

( Motor running control by external panel )

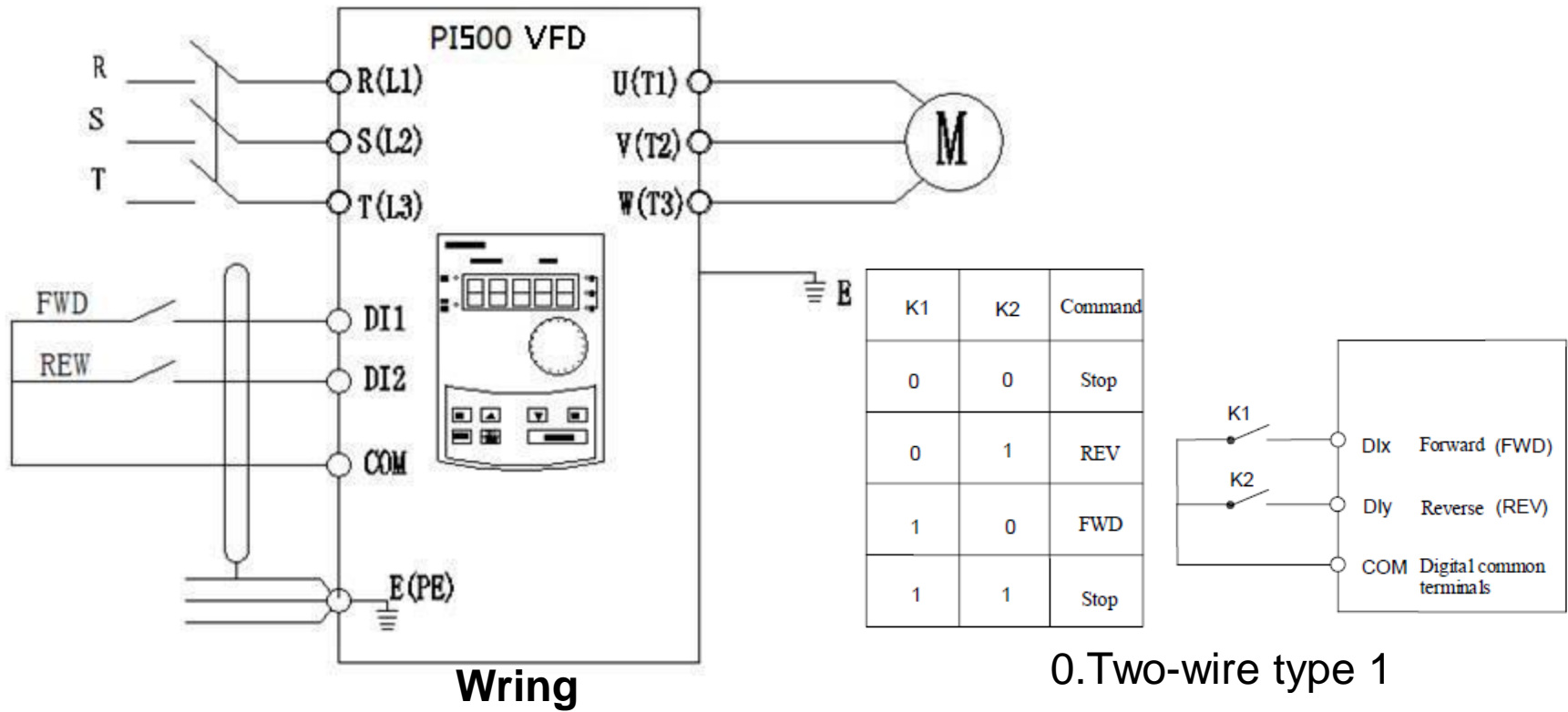

F0.11	command source selection	1:Terminal command channel (LED ON)	1
F0.24	running direction	0: same direction 1: opposite direction	0
F1.00	DI1function selection	1.Forward running direction	1
F1.01	DI2 function selection	2.Reverse running direction	2
F1.10	Terminal command mode	0.Two-wire type 1 /1.Two-wire type 2 2.Three-wire type 1 /3.Three-wire type	

# 10.three line control mode

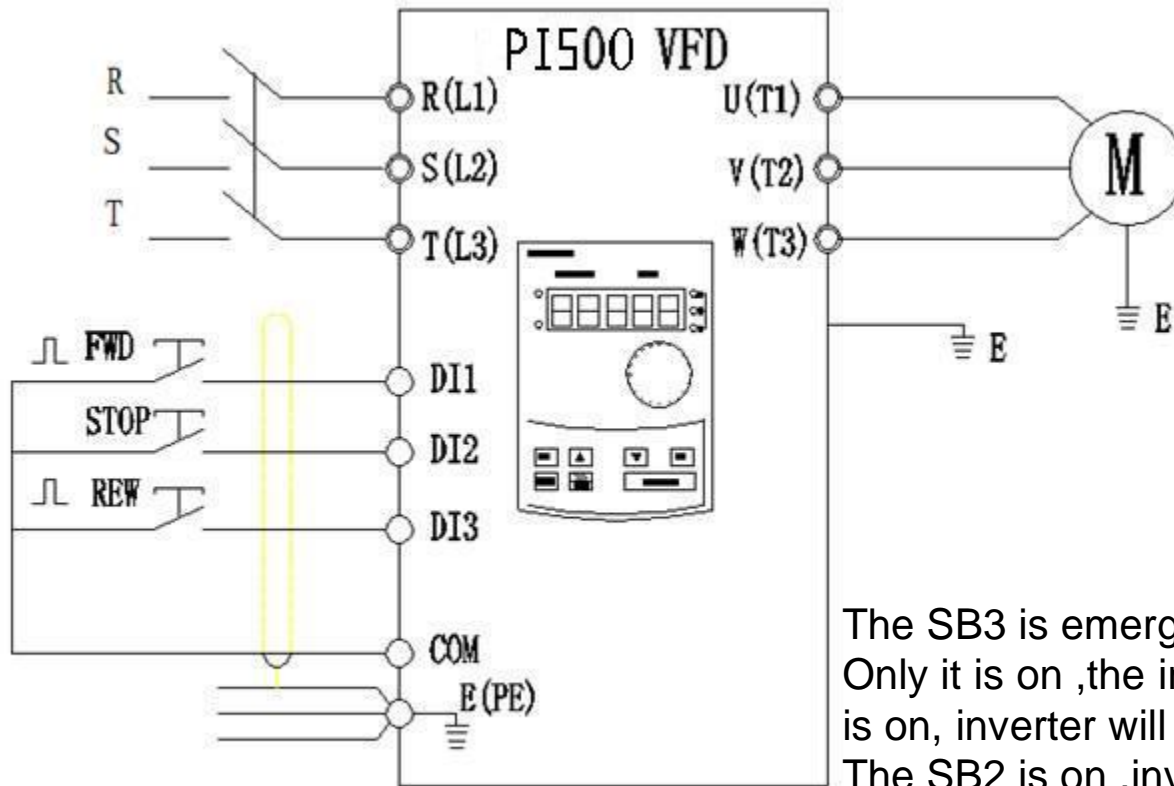

**Wiring**

SB2	SB1	SB3	running command
ON	↑		forward
ON		↑	Reverse
OFF	X	X	Stop

### 3 line control mode 1

The SB3 is emergency stop button, Only it is on ,the inverter is active. Otherwise.The SB1 is on, inverter will run in forward direction; The SB2 is on ,inverter will run in Reverse direction .

F0.11	command source selection	1:Terminal command channel (LED ON)	1
F1.00	DI1 function selection	1.Forward running direction	1
F1.01	DI2 function selection	3:Three line mode running control	3
F1.02	DI3 function selection	2.Reverse running direction	2
F1.10	Terminal command mode	2. three line control mode 1	2

# 11. Frequency setting with external potentiometer (AI1 for 0-10V\_Variable resistor)

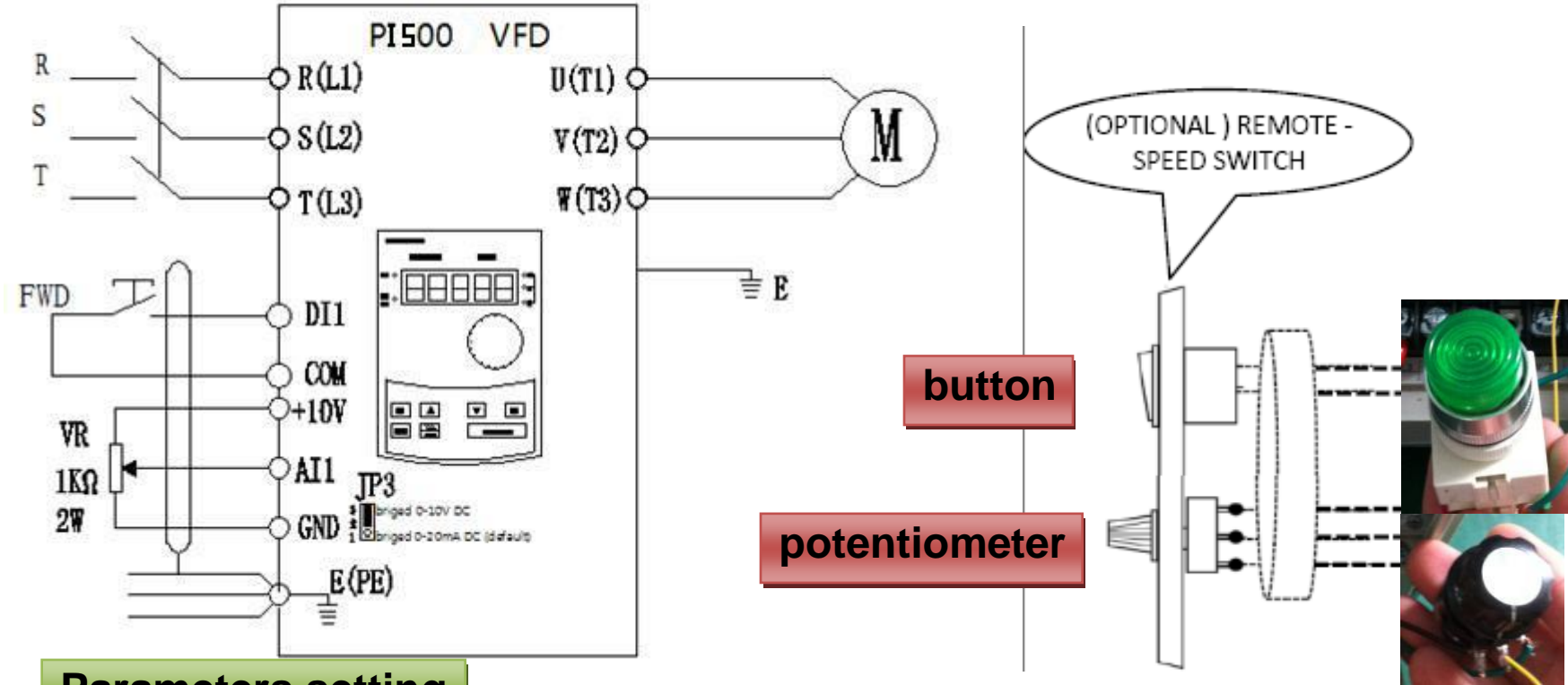

## Parameters setting

F0.11	command source selection	1:Terminal command channel (LED ON)	1
F0.03	frequency setting source selection	2:AI1 analog signal input	2
F1.00	DI1 function selection	1.Forward running direction	1
F1.10	Terminal command mode	1.two line control mode 2	1

# 12. Frequency setting by analog current (AI2)

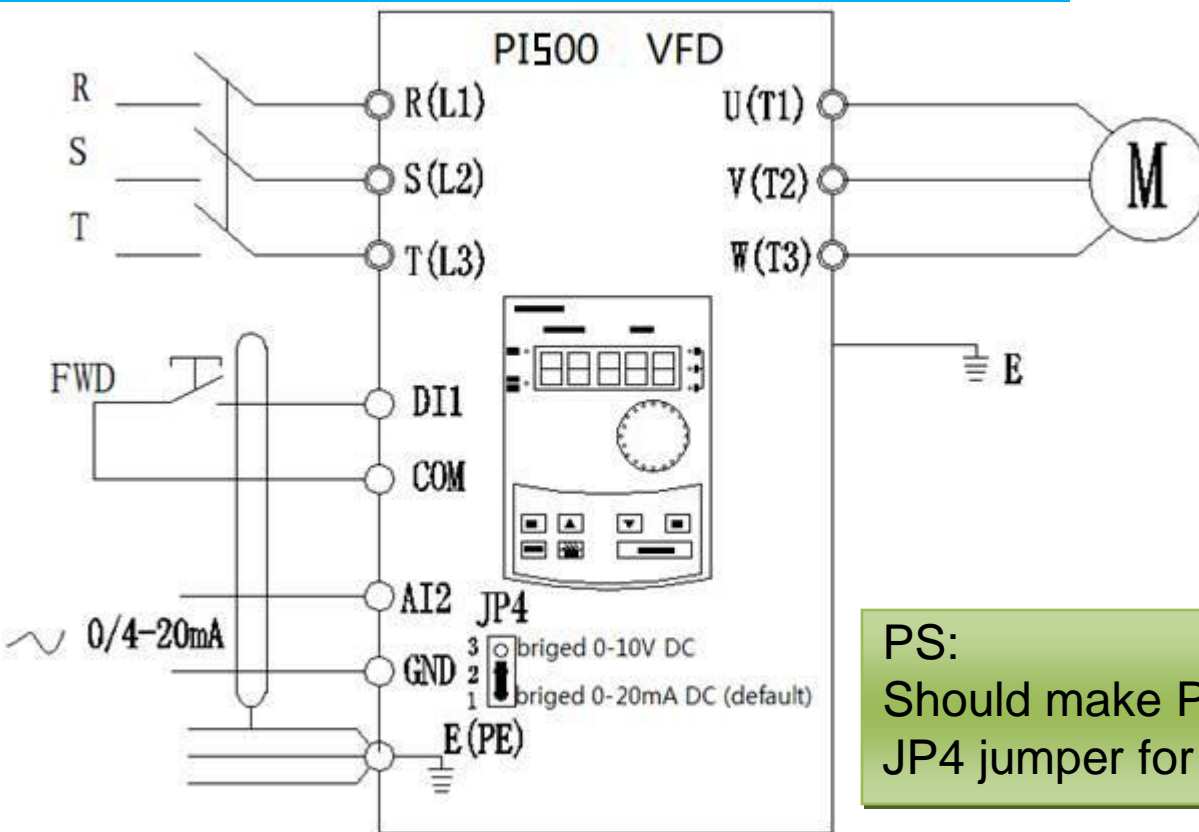

**PS:**  
Should make Pin1 and 2 short bridged of JP4 jumper for receiving 0-20mA signal.

## Parameters setting

F0.11	command source selection	1:Terminal command channel (LED ON)	1
F0.03	frequency setting source selection	3:AI2 analog signal input	3
F1.00	DI1 function selection	1.Forward running direction	1
F1.11	Terminal command mode	1.two line control mode 2	1

More setting please refer to F1 Group input and output.

# 13. Employ output analog signal for monitoring current, frequency, speed etc.

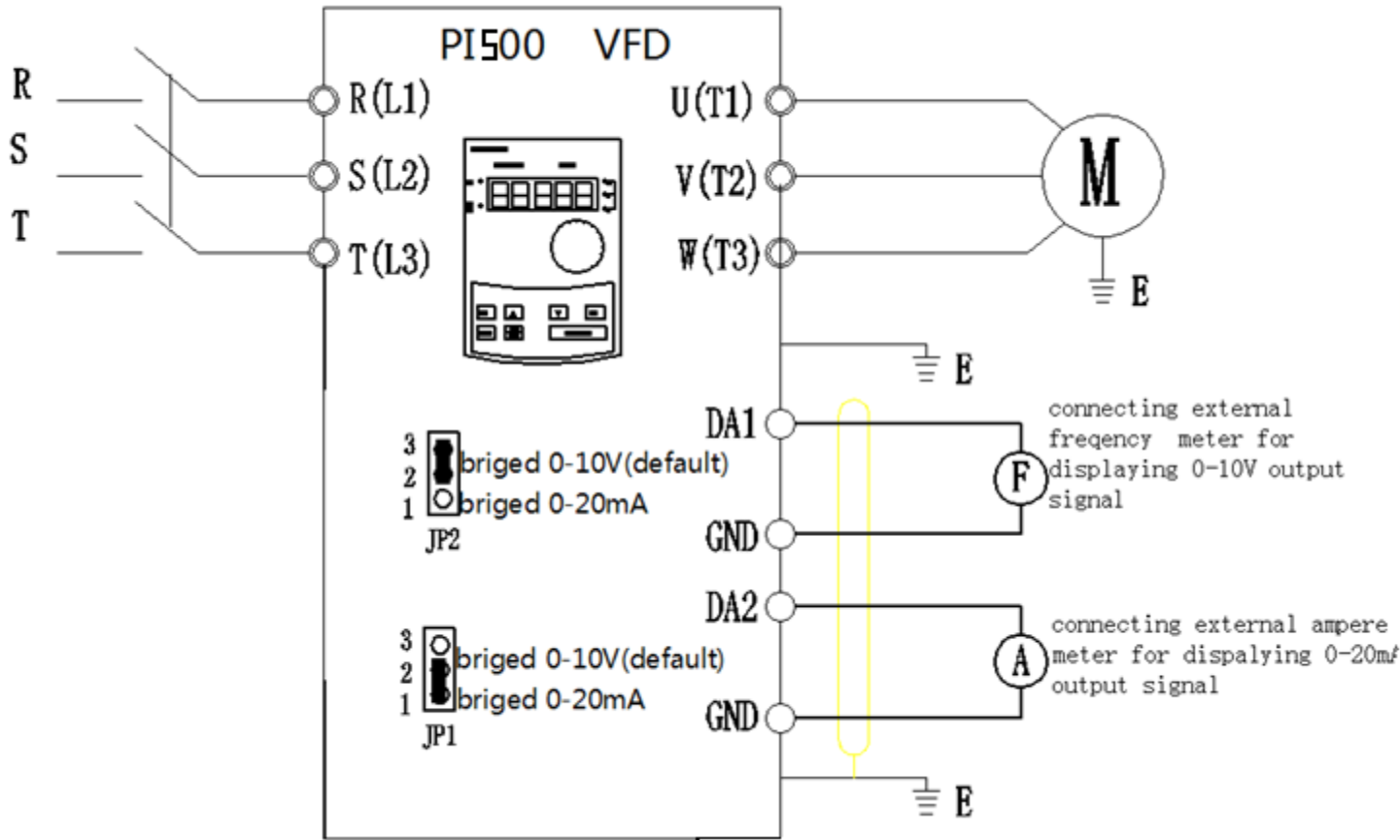

**Frequency meter**



**Ampere meter**

F2.07	DA1 Output Terminal	Actual frequency	0
F2.08	DA2 Output Terminal	Actual current	2
F2.16	DA1 Zero bias coefficient	-100%~+100%	0.0%
F2.17	DA1 gain	-10.00~+10.00	1.00
F2.18	DA2 Zero bias coefficient	-100.0%~+100.0%	0.00%
F2.19	DA2 gain	-10.00~+10.00	1.00



# 14. Multi-speed applying with I/O interface terminal

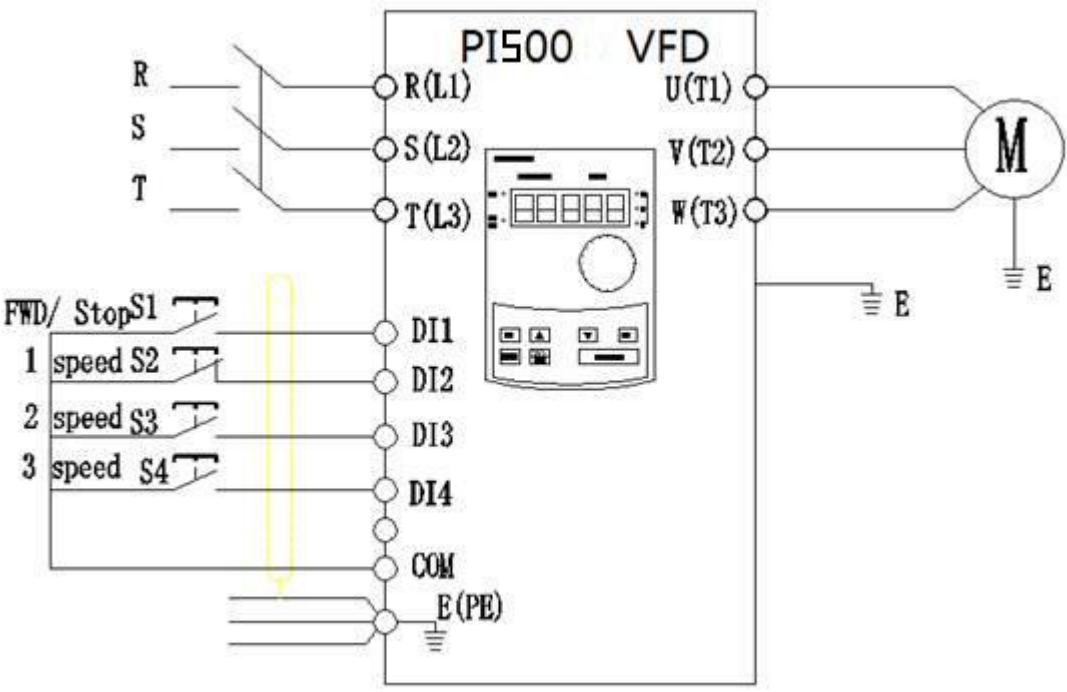

**MS terminal relative to Ms speed table.**

MS1	MS2	MS3	MS4	
OFF	OFF	OFF	OFF	F11.00
OFF	OFF	OFF	ON	F11.01
OFF	OFF	ON	OFF	F11.02
OFF	OFF	ON	ON	F11.03
OFF	ON	OFF	OFF	F11.04
OFF	ON	OFF	ON	F11.05
OFF	ON	ON	OFF	F11.06
OFF	ON	ON	ON	F11.07
ON	OFF	OFF	OFF	F11.08
ON	OFF	OFF	ON	F11.09
ON	OFF	ON	OFF	F11.10
ON	OFF	ON	ON	F11.11
ON	ON	OFF	OFF	F11.12
ON	ON	OFF	ON	F11.13
ON	ON	ON	OFF	F11.14
ON	ON	ON	ON	F11.15

CODE	Description	Range of setting	Refer. value
F0.11	command source selection	1:Terminal command channel (LED ON)	1
F0.03	frequency setting source selection	6.multiple-speed frequency setting	6
F1.00	DI1 function selection	Forward rotation	1
F1.01	DI2 function selection	MS speed terminal 1	12
F1.02	DI3 function selection	Ms speed terminal 2	13
F1.03	DI4 function selection	Ms speed terminal 3	14
E1.01	MS speed 1	-100.0~100.0%	20
E1.02	MS speed 2	-100.0~100.0%	50

# 15. Frequency UP and Down controlled by I/O interface terminal board

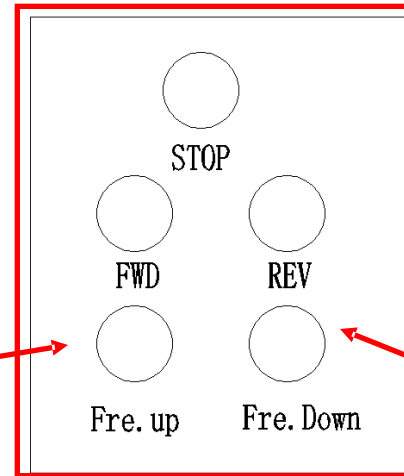
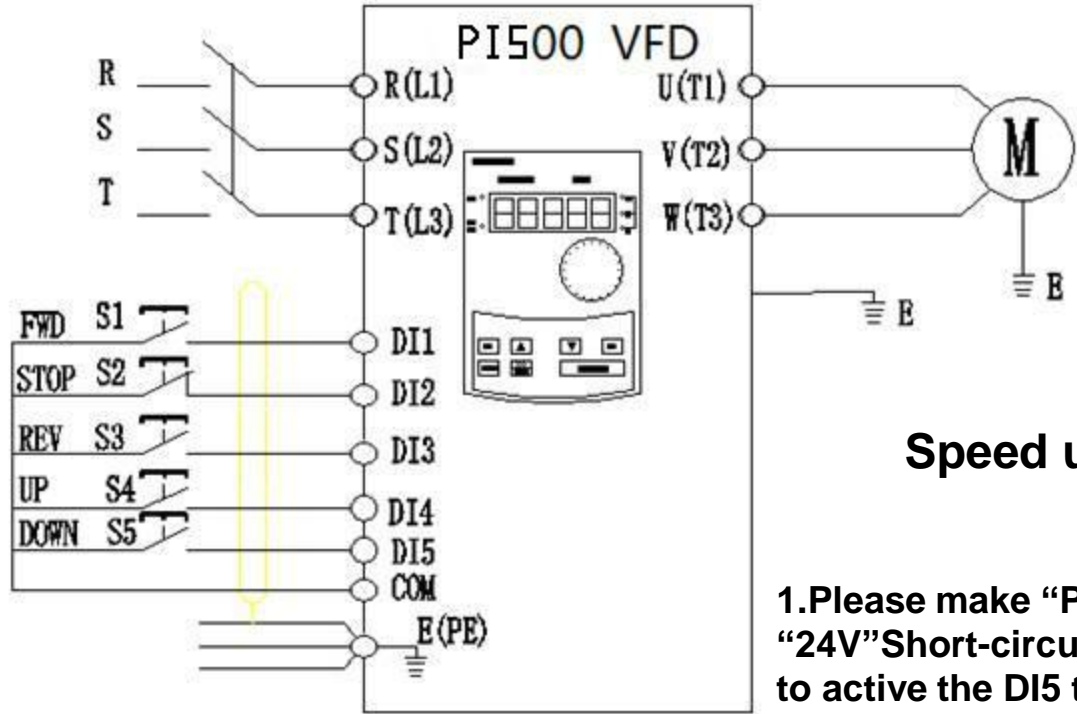

1. Please make "PLC" and "24V" Short-circuit first to active the DI5 terminal

**Control panel**

CODE	Description	Range of setting	Refer. value
F0.11	command source selection	1:Terminal command channel (LED ON)	1
F1.00	DI1 function selection	Forward rotation	1
F1.01	DI2 function selection	Reverse rotation	2
F1.03	DI3 function selection	6. Terminal UP	6
F1.04	DI4 function selection	7. Terminal DOWN	7
F1.11	change rate of terminal up and down	0.01 ~ 100.00Hz/s	1.0Hz

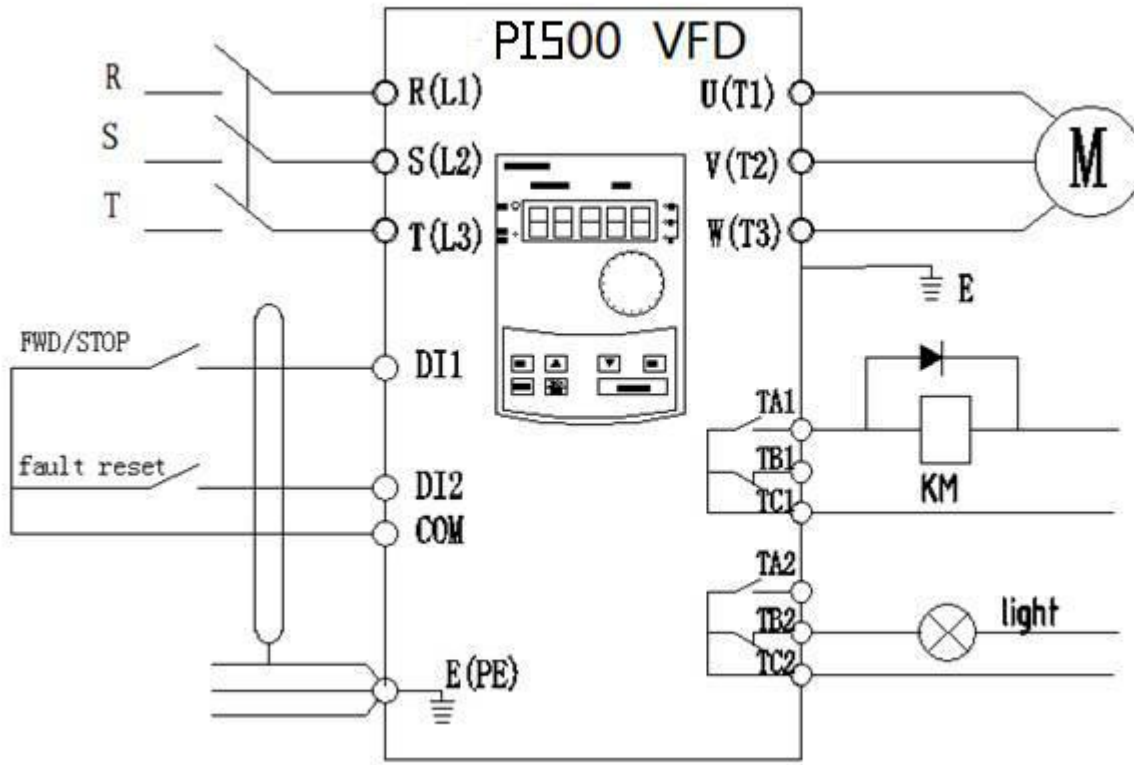

When alarm happen ,the normal open relay will close ,the KM1 will be on, the main switch will be open and cut off the main circuit .The alarm light will be on as well to show there is alarm .

5A/250V  
5A/30VDC

5A/250V  
5A/30VDC

**Parameters setting**

CODE	Description	Range of setting	Refer. value
F0.11	command source selection	1:Terminal command channel (LED ON)	1
F1.00	DI1 function selection	Forward rotation	1
F1.01	DI2 function selection	Fault reset	9
F2.02/F2.05	Relay output selection	0: No output 1:motorforward running 2.Fault output 3:Frequency level detection FDT output 4:Frequency arrival 5:in Zero speed operation ...	2

# 16.2.Application of multi-function output 2. ( frequency arrival and frequency detecting )



VFD 1 will start once the fre. of VF2 arriving at 30Hz,stop when fre. of VF2 limit 25Hz.

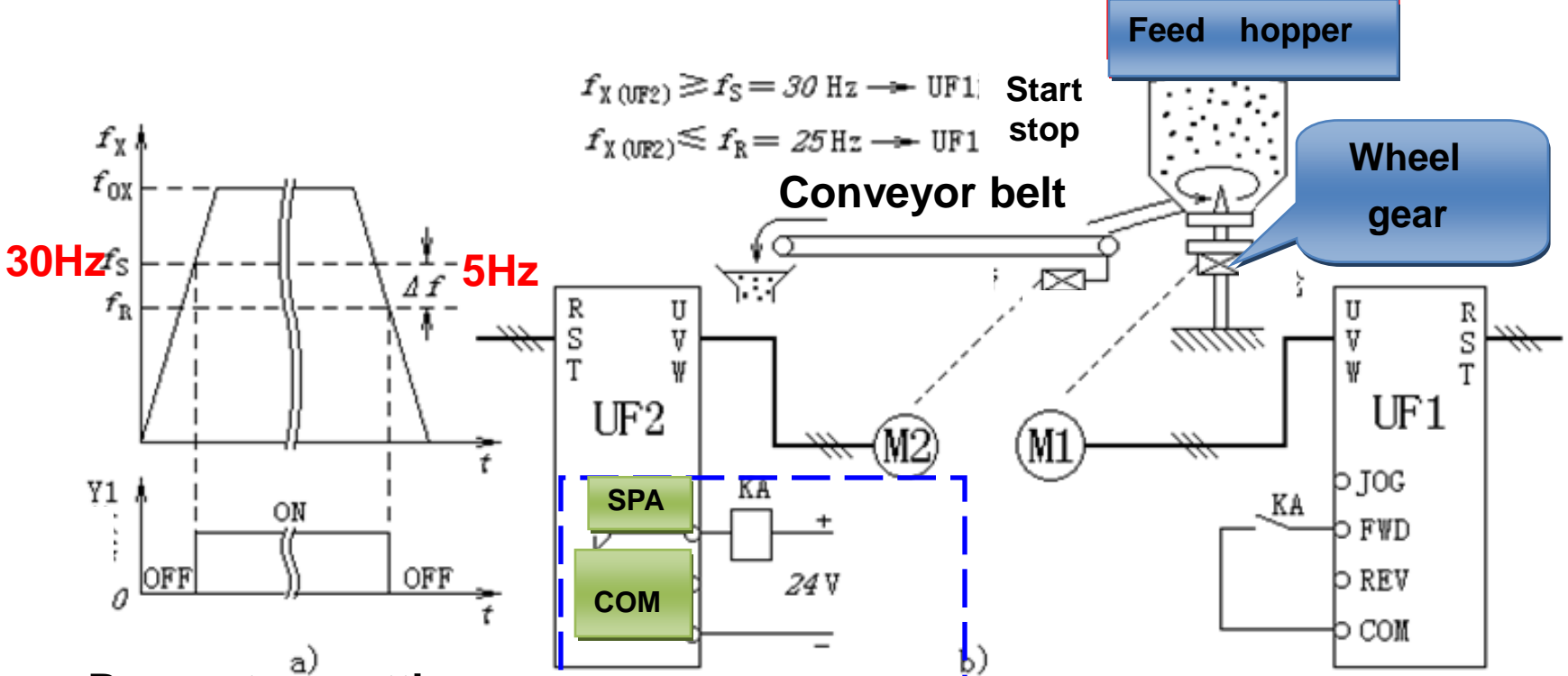

CODE	Description	Range of setting	Refer. value
F0.11	command source selection	1:Terminal command channel (LED ON)	1
F1.00	D11 function selection	Forward rotation	1
F2.02	Relay output selection	4:Frequency level detection FDT output	4
F7.23	(FDT) frequency detection value	0.00~U0.10(Maximum frequency)	35Hz
F7.24	FDT detection hysteresis	0.0%~100.0%(FDT level)	5Hz

# 17.1 PID control for constant pressure water supply -electrical diagram ( 0-10V signal feedback )

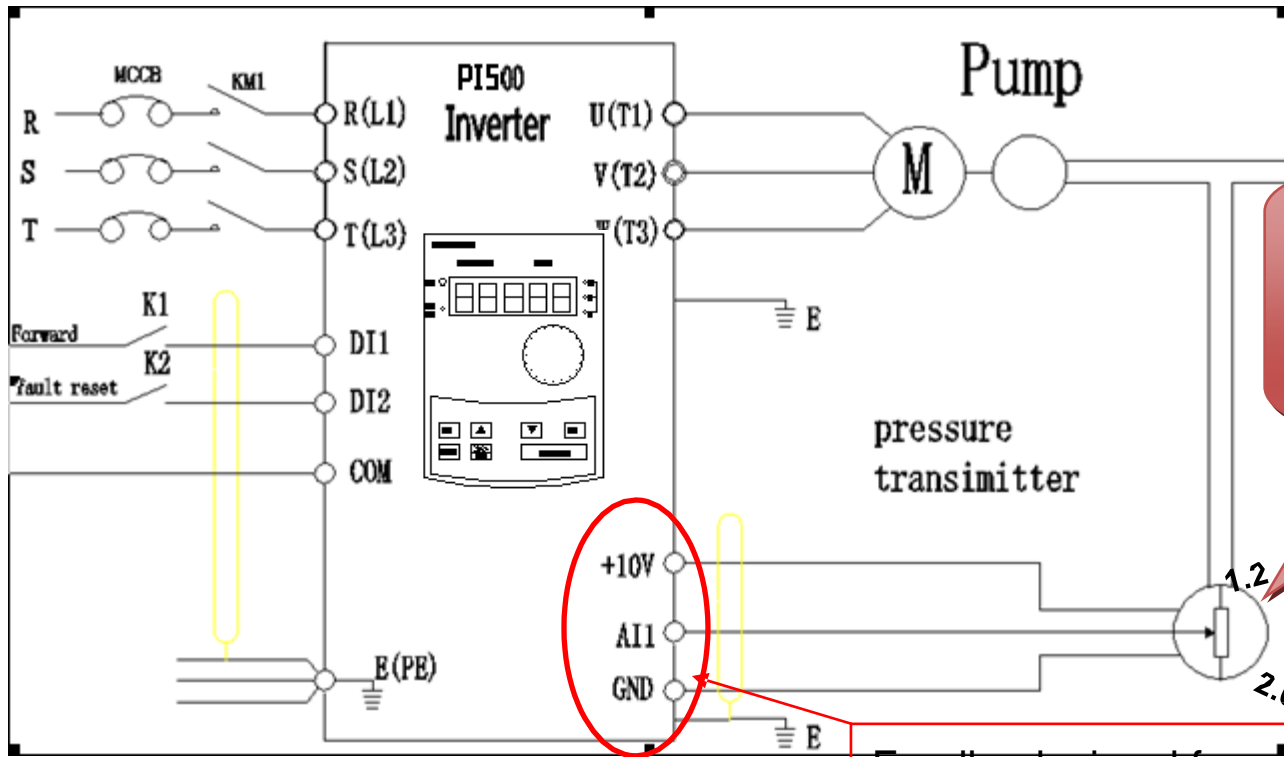

The maximum range Of meter is 2 Mbar. It is need to keep 1.2 Mbar Pressure all the time . E2.01 should be set to 1.2/2.0x100%

Feedback signal from pressure transmitter

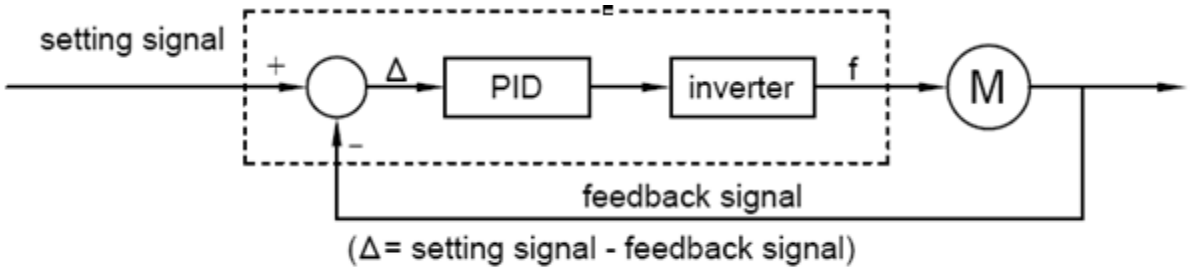

negative action, when  $\Delta > 0$  is positive, frequency rises and when  $\Delta < 0$  is negative, frequency falls. For constant Pressure water supply.

# 17.2.PID control for constant pressure water supply -electrical diagram ( 0-20mA signal feedback )

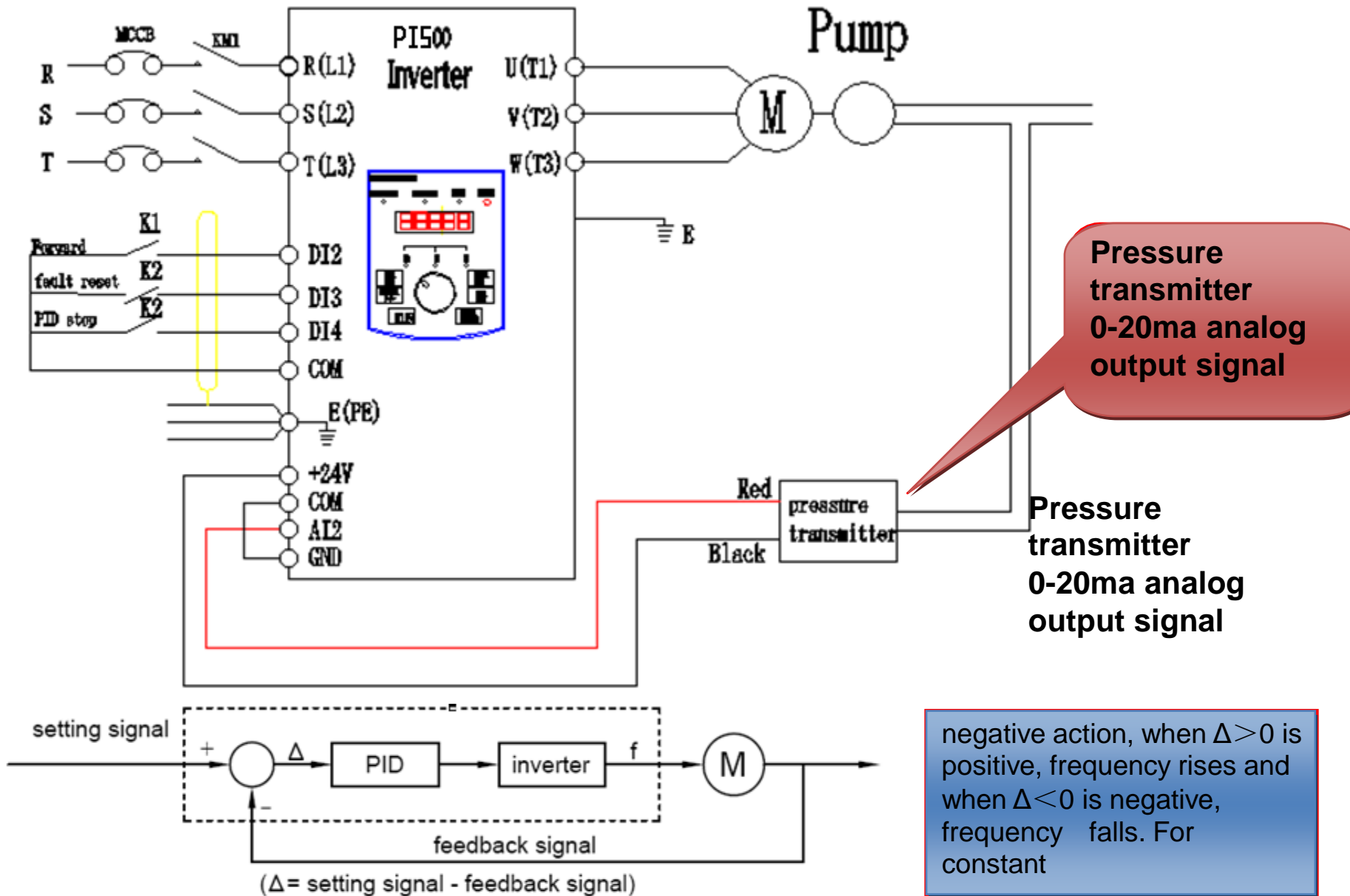

# PID control for constant pressure water supply

## Parameters setting

F0.00	Control mode	2:V/F	2
F0.03	frequency setting source selection	8: PID control setting	8
F0.13	acceleration time	0.1 ~ 3600.0s	25
F0.14	deceleration time	0.1 ~ 3600.0s	25
E2.00	PID reference source	key board (E2.01)	0
E2.01	PID value set by keyboard	0.0% ~ 100.0%	60
E2.02	PID feedback source	0/1:analog input feedback signal AI1 /AI2	0/1
E2.03	PID action direction	0:positive action	0
E2.04	PID setting feedback range	0 ~65535	1600
E2.05	PID inversion cutoff frequency	0.00 to F0.19(maximum frequency)	2
E2.13	proportional gain (Kp)	0.00 ~ 100.00	100.00
E2.14	integration time (Ti)	0.00 ~ 100.00	0.25s
F3.07	Stop mode	0: Deceleration parking 1: Free stop	1
F0.21	Upper limit frequency		50
F0.23	Lower limit frequency		25



## 18. PI500 apply in air compressor retrofitting with PID control function.



The air compressor variable frequency control system is mainly composed of a frequency converter, a pressure sensor (pressure transmitter).

A pressure sensor component is first used to test the pressure in the reservoir. Next, the detection display instrument sends the output pressure analog signal to the frequency converter, which then compares to the feedback signal and the given objective signal, using the internal PID of the frequency converter to carry out automatic output frequency regulation, allowing for automatic adjustment of compressor motor speed and output power. This creates a closed-loop feedback system that maintains constant pressure and automatic control in the pipe network.

# Wirings of electrical diagram with 0-20mA type of pressure transmitter

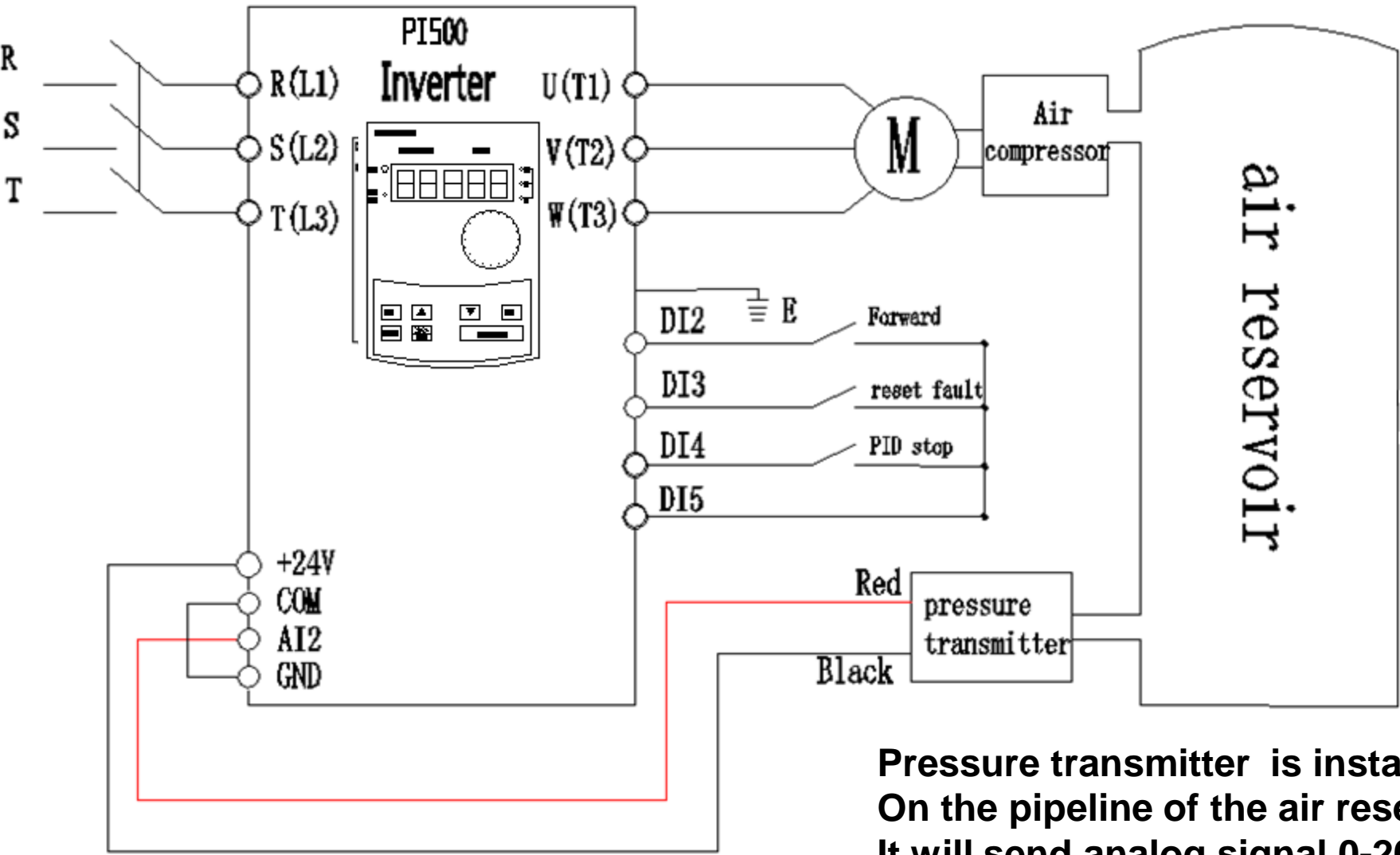

**Pressure transmitter is installed  
On the pipeline of the air reservoir  
It will send analog signal 0-20mA  
to inverter .**

# Wirings of electrical diagram with 0-10V type pressure transmitter

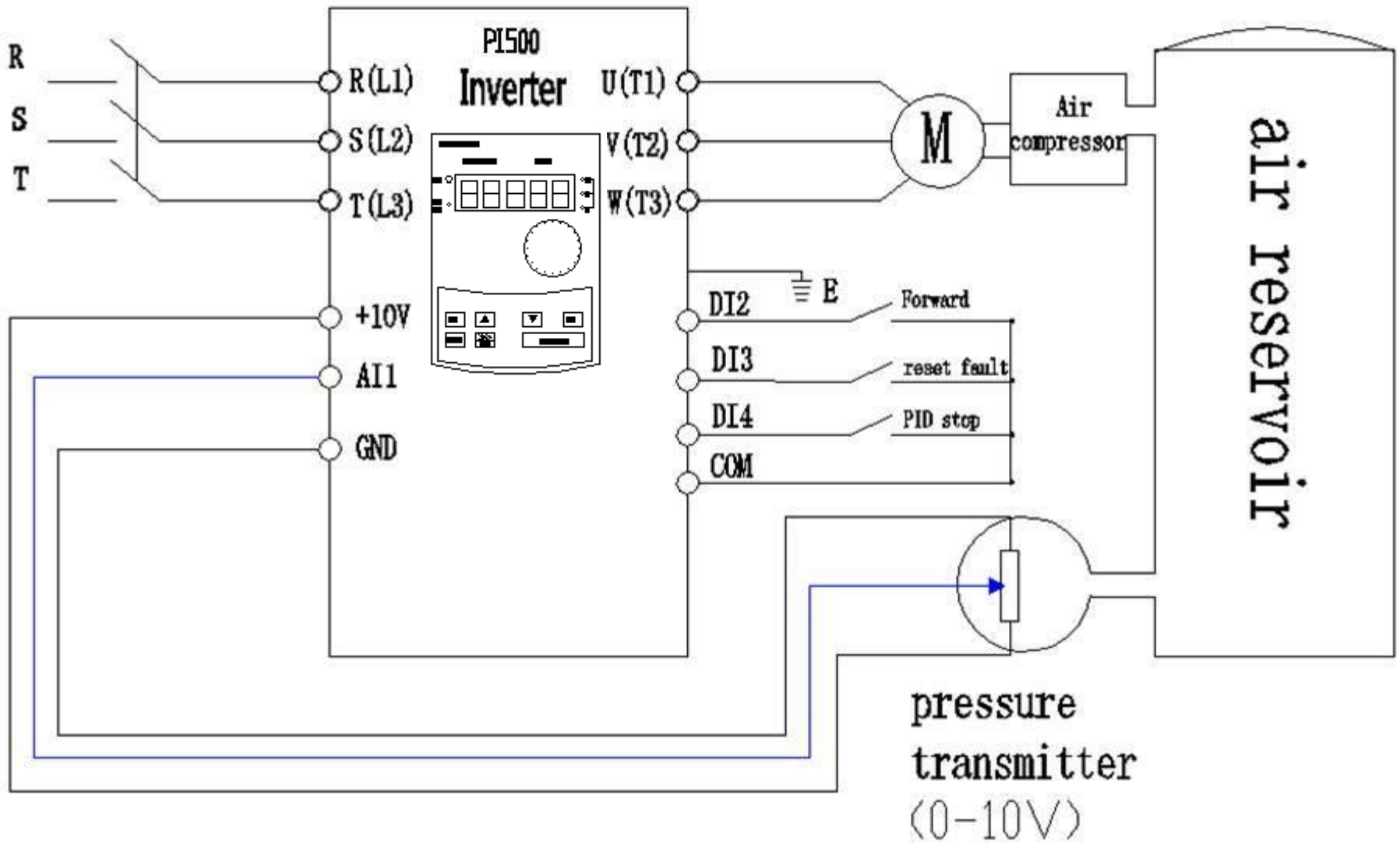

# 19. Powtran PI500 high performance vector control drive using Well in crane.

**PI9100 high performance vector control drive**



**Motor and load's detail.**

**Crane in one factory**



**Powtran PI500 055G3 on site**

# Wiring of PI500 series inverters in crane.

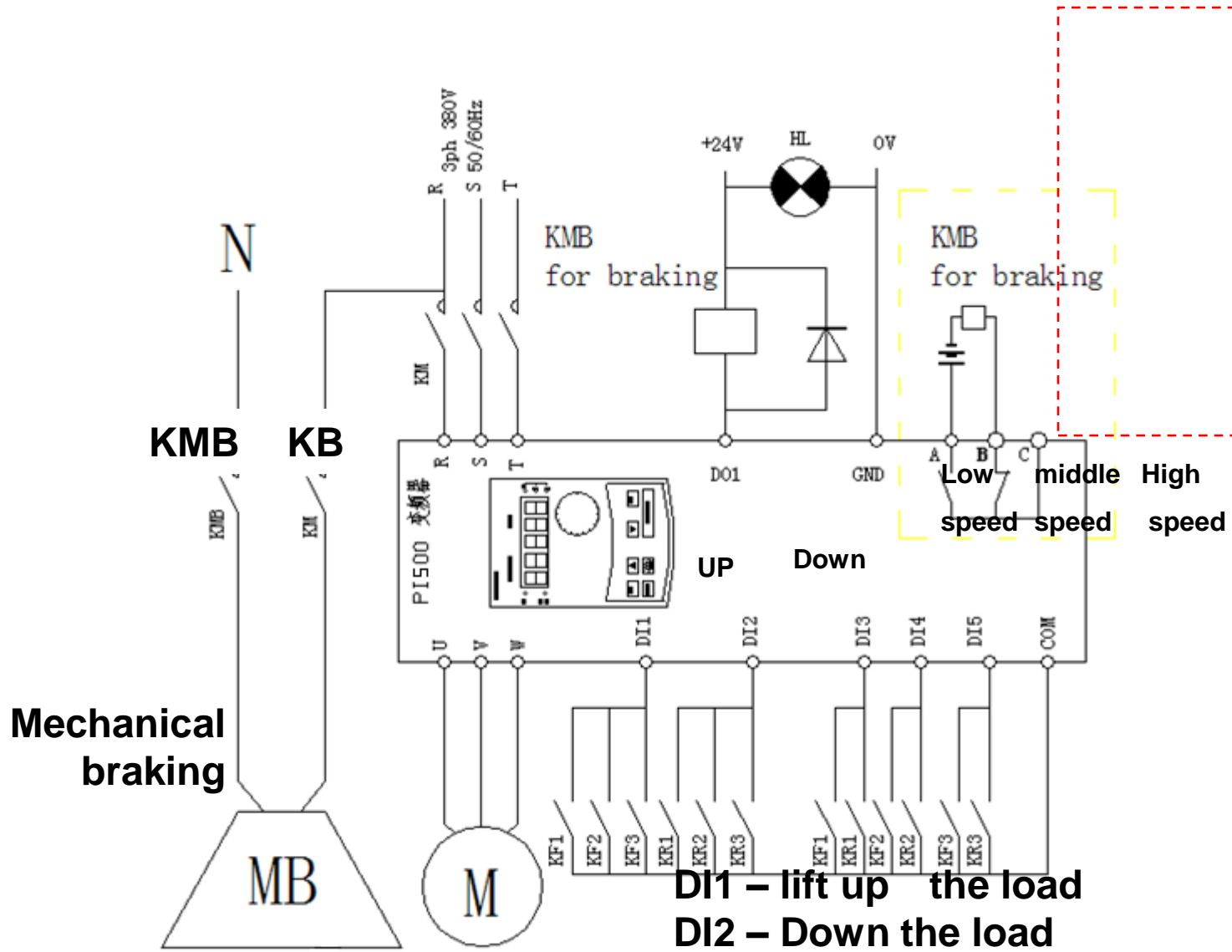

**MB also can  
Be connect  
To this relay.**

**DI1 – lift up the load**  
**DI2 – Down the load**

**DI3- MSS1**  
**DI4- MSS3**  
**DI5- MSS3**

+24V

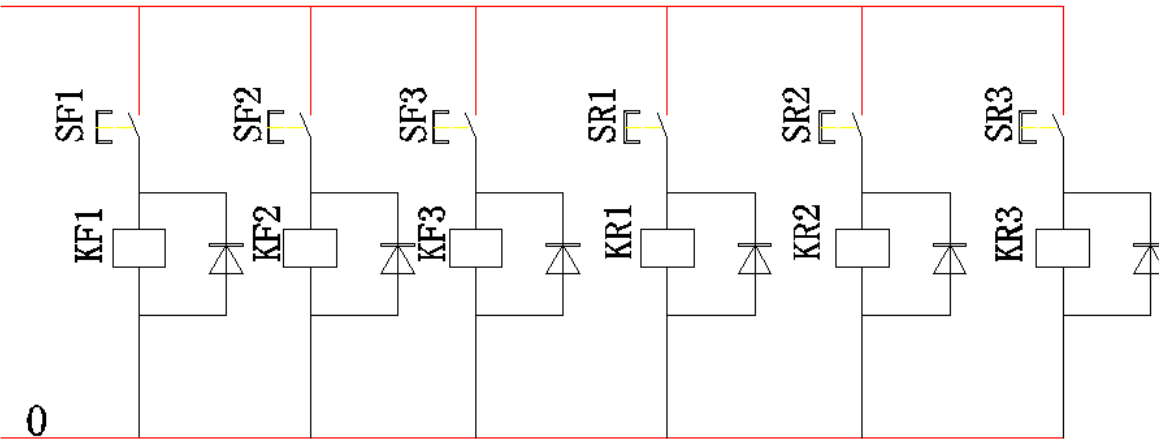

DI1 – lift up the load

DI2 – Down the load

DI3- MSS1 for low speed running

DI4-MSS 2 for middle speed running

DI5-MSS 3 for high speed running .

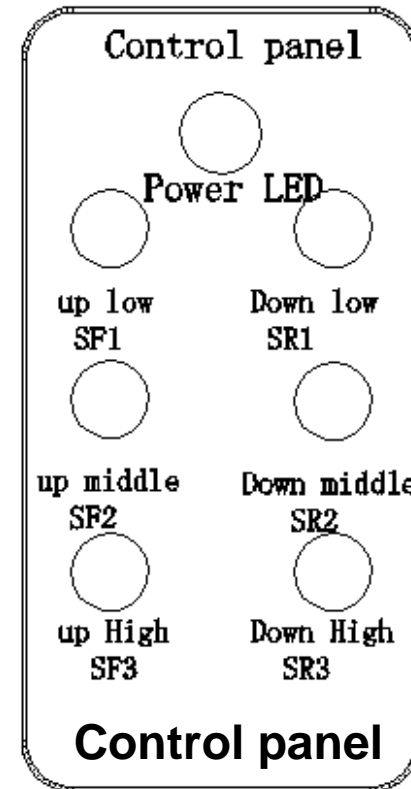

The key feature of PI500 for lifting application.

1. V/F, sensorless vector control. Sensor vector Control, torque control
2. Large torque output under low speed
3. Quick torque responsive time
4. Quick current limit, make sure no “oc” trip.
5. Multiple I/O function programming.

1. If the load can be disconnect from motor, suggest select F0.00

For 0( vector control W/O PG).

**In this control mode, 150% rated output torque under 0.5Hz can be achieved. Quick Acceleration time without OC current trip is available.**

Before function parameters setting, please perform auto tuning to get precision parameter of motor.

1. Disconnect the load from motor .(This is important ,otherwise can't get the Motor parameters accurately ,the perform of vector control maybe not good.
2. put the b.01 , b0.02, b0.03, b0.04, b0.05 according nameplate of motor.
3. Put the b0.27to 2, the LED of TUN will on in the keyboard ,and then press the RUN key ,motor will start auto-turning automatic .
4. It will display „END” in the menu at the end of auto-turning .it means the autoTurning has performed successfully .

Note: If the load are hard to disconnect, please set B0.27 for 1 to start auto tuning. If the performance is not good, we have no choice select F0.00 for 2 ) V/F control.

<b>CODE</b>	<b>Description of Code</b>	<b>Range of setting</b>
b0.01	rated power	15.000
b0.02	rated frequency	50Hz
b0.03	rated rotation speed	1450
b0.04	rated voltage	380V
b0.05	rated current	32A
b0.27	motor auto-turning selection	2. Asyn motor parameter Comprehensive auto running



# Parameters setting table :

CODE	Description of Code	Range of setting	Refer. value
F0.00	Control mode	0:Vector control mode	0
F0.11	command source selection	1:Terminal command channel (LED ON)	1
F0.03	frequency setting source selection	6:Multiple speed setting	6
F0.13	acceleration time	0.1~3600.0s	1
F0.14	deceleration time	0.1~3600.0s	0.1
F1.00	DI1 function selection	1:Forward running direction	1
F1.01	DI2 function selection	2:Reverse rotation (REV)	2
F1.02	DI3 function selection	12:MS speed terminal 1	12
F1.03	DI4 function selection	13:MS speed terminal 2	13
F1.04	DI5 function selection	14:MS speed terminal 3	14
F2.04	SPA collector output selection	4:Frequency level detection FDT output	4
F7.23	Frequency detection value	0.00Hz F0.19( maximum frequency)	2
F7.24	Frequency detection hysteresis (FDT1)	0.0% to 100% (FDT1 level0	5%
E1.01	MS speed 1	-100.0~100.0%	10
E1.02	MS speed 2	-100.0~100.0%	50
E1.04	MS speed 4	-100.0~100.0%	100

More parameters need to be set in some lifting application.

1. Need fault reset by I/O terminal, F1.05 (DI6) set to 9 (please refer to page 103).
2. Need emergency stop button, F1.05(DI6) set to 47.( no enough DI input terminal)
3. Need DC braking function. To get braking torque at starting or stop mode.  
please refer to the parameters F3.00 to F3.06 for starting, F3.08 to F3.12.for stoping.  
It can help us get position control when stopping using DC braking function.

**Note: 1. If inverter running in V/F mode, ( F0.00=2), there not enough starting torque output under low speed, only 150% rated torque output under 4 Hz. Please **et F4.01 for 15.** and configure **F7.23 for 4Hz**, and **F7.24 for 2.****

**2. braking unit and braking resistor must be connect.( deceleration time is 0.1s)**

**3. PI500 inverter also can run in vector control with PG feedback loop (F0.00=1).**

**if encoder of motor is available, it can get bigger output torque under low speed ( 180% rated torque under 0Hz), running speed more stable.**

**4. The rated power of inverter should bigger two range than motor's. For example, It will be better, 15Kw motor select 22Kw of inverter, 5.5 KW of motor should select 11Kw of inverter's....**